

FRASER COLD PLUNGE

STAINLESS STEEL IN GROUND

SPECIFICATIONS

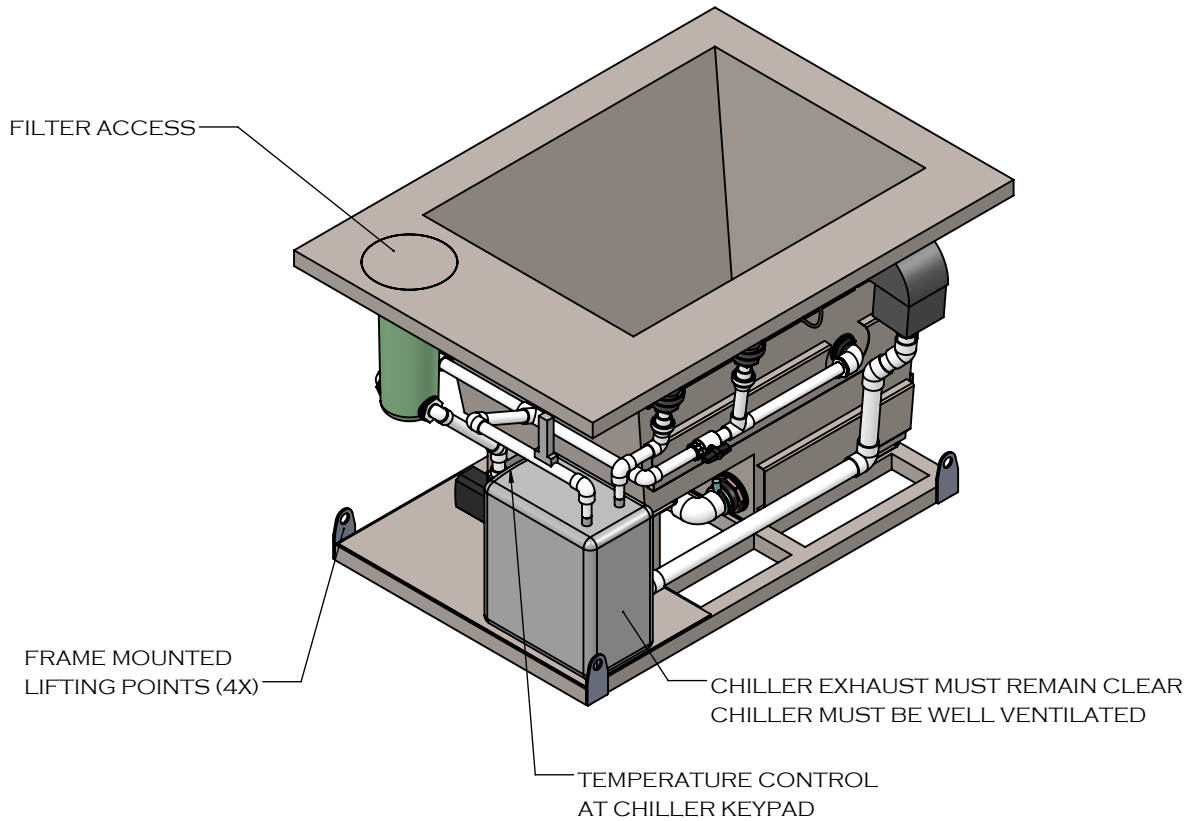

FEATURES:

- 316L STAINLESS STEEL SHELL WITH 304L STAINLESS STEEL FRAME
- 1 BATHER CAPACITY
- FULLY INSULATED SHELL
- RIGID FOAM COVER WITH R-15 INSULATION AND ASTM CERTIFICATION
- UV LIGHT & HYDROGEN PEROXIDE SANITIZATION
- OVERALL DIMENSIONS: 62" x 44" x 39"
- WATER CAPACITY: 124 GALLONS
- EMPTY WEIGHT: 772 LBS
- FULL WEIGHT: 1,805 LBS
- 1/4 HP WATER CHILLER

POWER REQUIREMENTS:

- (1X) 120V 20A GFCI SERVICE AT COLD PLUNGE

