

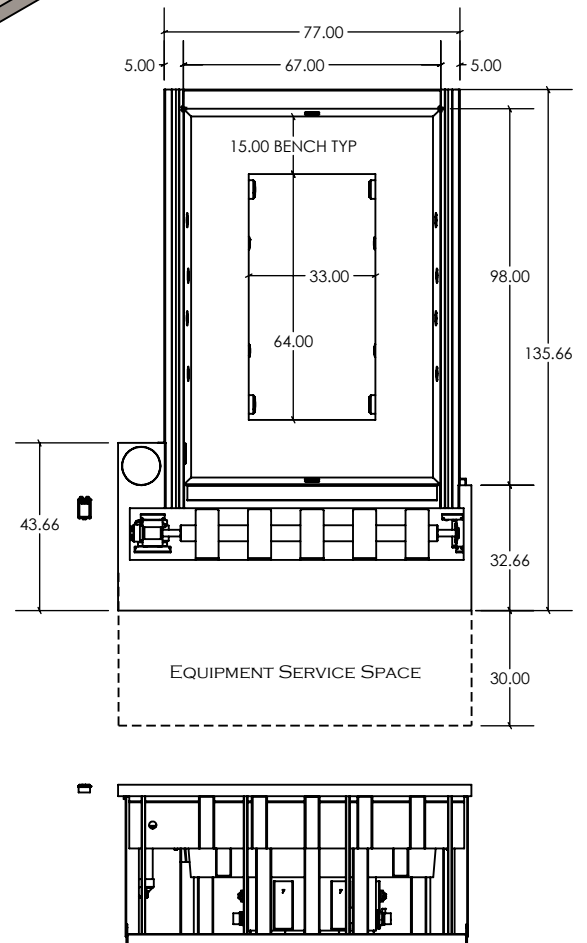

KENOSHA PORTABLE SPA

STAINLESS STEEL INGROUND WITH AUTOCOVER

SPECIFICATIONS

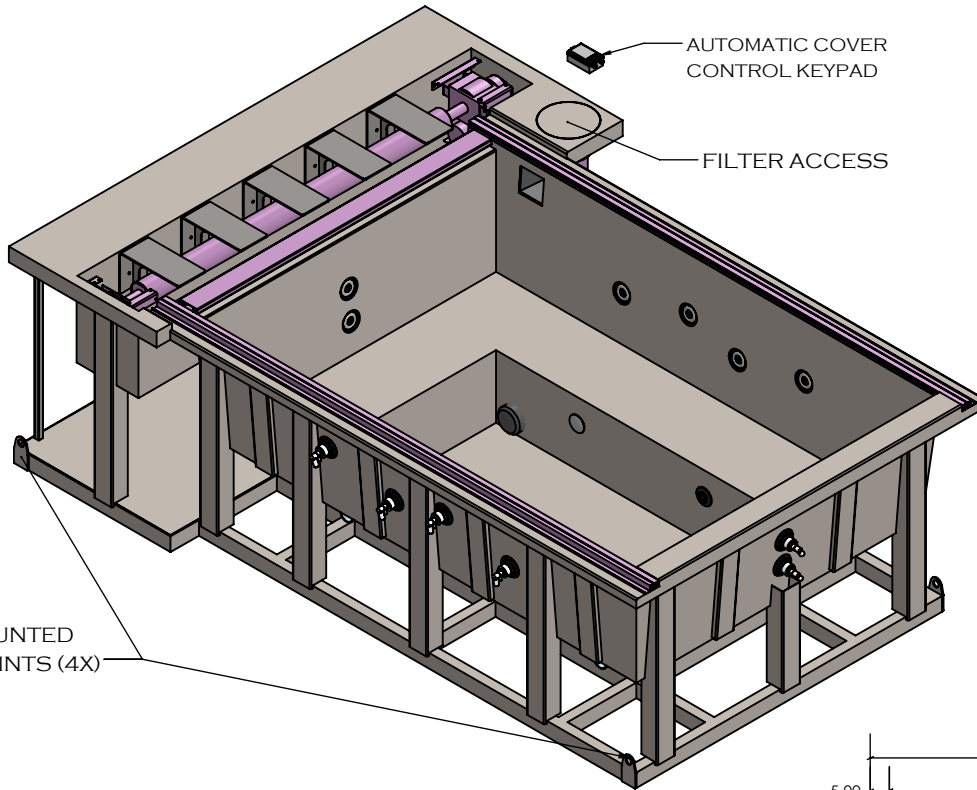

FEATURES:

- 316L STAINLESS STEEL SPA SHELL WITH 304L STAINLESS STEEL FRAME
- 6-8 BATHER CAPACITY
- LED LIGHTING
- 12 HYDROTHERAPY JETS
- FULLY INSULATED WITH 2-PART POLYURETHANE FOAM (NOT SHOWN)
- RIGID FOAM COVER WITH R-15 INSULATION AND ASTM CERTIFICATION
- UV LIGHT & HYDROGEN PEROXIDE SANITIZATION
- OVERALL DIMENSIONS: 136" x 92" x 42"
- WATER CAPACITY: 607 GALLONS
- EMPTY WEIGHT: 1,807 LBS
- FULL WEIGHT: 6,875 LBS

CERTIFICATIONS:

STAINLESS STEEL & COPPER SHELLS:

- IAPMOEGS LISTING FOR UL 1795 AND CSA C22.2 STANDARDS

POWER REQUIREMENTS:

- (1x) 230V 40A GFCI SERVICE AT EQUIPMENT FOR SPA CONTROL
- (1x) 230V 60A GFCI SERVICE AT EQUIPMENT FOR 11 KW ELECTRIC HEATER
- (1x) 120V 15A GFCI SERVICE AT AUTOCOVER KEYPAD
- SPA SHELL AND ALL EQUIPMENT TO BE BONDED W/ MIN. #6AWG BARE COPPER CONDUCTOR



KENOSHA PORTABLE SPA

COPPER INGROUND WITH AUTOCOVER

SPECIFICATIONS

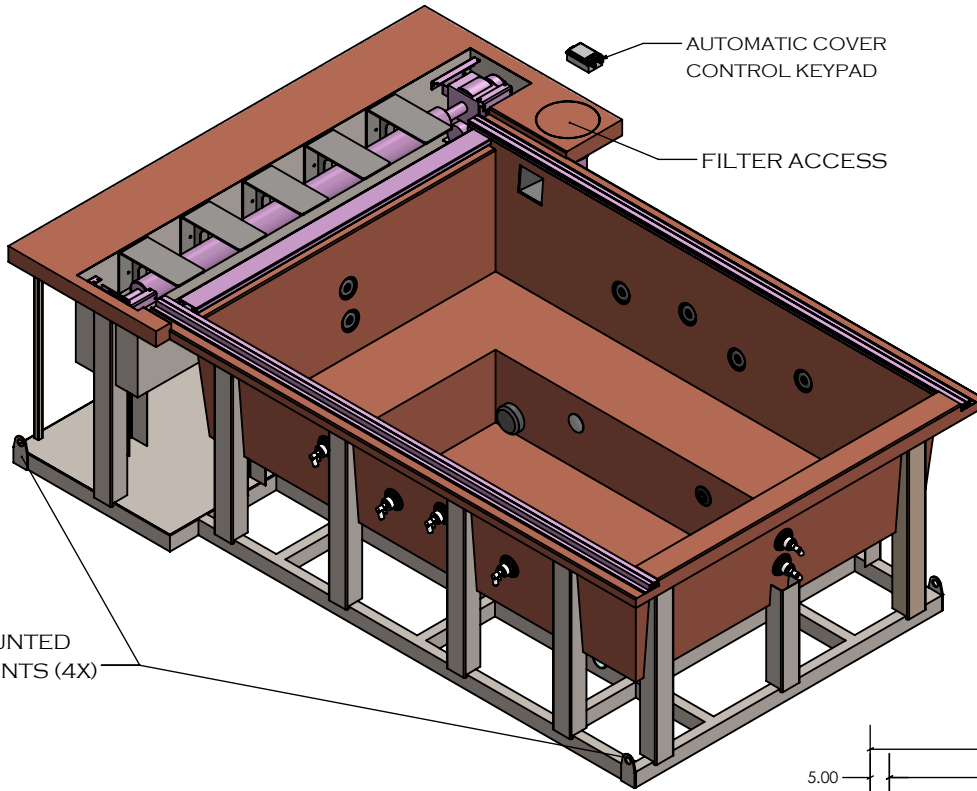

FRAME MOUNTED LIFTING POINTS (4X)

AUTOMATIC COVER CONTROL KEYPAD

FILTER ACCESS

FEATURES:

- COPPER SPA SHELL WITH 304L STAINLESS STEEL FRAME
- 6-8 BATHER CAPACITY
- LED LIGHTING
- 12 HYDROTHERAPY JETS
- FULLY INSULATED WITH 2-PART POLYURETHANE FOAM (NOT SHOWN)
- RIGID FOAM COVER WITH R-15 INSULATION AND ASTM CERTIFICATION
- UV LIGHT & HYDROGEN PEROXIDE SANITIZATION
- OVERALL DIMENSIONS: 136" x 92" x 42"
- WATER CAPACITY: 607 GALLONS
- EMPTY WEIGHT: 1,8.5 LBS
- FULL WEIGHT: 6,905 LBS

CERTIFICATIONS:

STAINLESS STEEL & COPPER SHELLS:

- IAPMOEGS LISTING FOR UL 1795 AND CSA C22.2 STANDARDS

POWER REQUIREMENTS:

- (1X) 230V 40A GFCI SERVICE AT EQUIPMENT FOR SPA CONTROL
- (1X) 230V 60A GFCI SERVICE AT EQUIPMENT FOR 1.1 KW ELECTRIC HEATER
- (1X) 120V 15A GFCI SERVICE AT AUTOCOVER KEYPAD
- SPA SHELL AND ALL EQUIPMENT TO BE BONDED W/ MIN. #6AWG BARE COPPER CONDUCTOR

